

Saskatchewan Ministry of Energy and Resources  
Minister's Order 252/18

**Approval of Directive S-01: Saskatchewan Upstream Petroleum Industry Storage Standards  
Section 17, The Oil and Gas Conservation Act**

In accordance with clauses 17(1)(k) and (n) of *The Oil and Gas Conservation Act* (the Act), I hereby do order that:

- i) the requirements set out in Schedule A apply to all licensees of wells and facilities licensed under the Act;
- ii) the document shown in Schedule A be known as "*Directive S-01: Saskatchewan Upstream Petroleum Industry Storage Standards*" or "*Directive S-01*"; and
- iii) any previous orders relating to the requirements set out in Schedule A are rescinded.

Dated at Regina, Saskatchewan this 24 day of August 2018.

  
Per: Minister of Energy and Resources  
Doug MacKnight  
Assistant Deputy Minister  
Petroleum and Natural Gas



---

# Saskatchewan Upstream Petroleum Industry Storage Standards

---

Directive S-01

---

November 2015

Revision 2.0

---

## Governing Legislation:

Act: *The Oil and Gas Conservation Act*

Regulation: *The Oil and Gas Conservation Regulations, 2012*

Order:

---

**Record of Change**

| <b>Revision</b> | <b>Date</b>   | <b>Description</b>                                   |
|-----------------|---------------|--|
| 0.0             | June 1, 2010  | Original   |
| 1.0             | June 1, 2011  | Revision   |
| 2.0             | November 2015 | Update to facilitate implementation of IRIS in 2015. |

## Contents

|       |  |    |
|-------|--|----|
| 1.    | General Discussions.....   | 5  |
| 1.1   | General Discussions.....   | 5  |
| 1.2   | Applicable Facilities.....   | 6  |
| 1.3   | Applicable Materials.....  | 6  |
| 1.4   | Exempted Materials.....  | 6  |
| 1.5   | Storage Duration.....  | 7  |
| 1.6   | Temporary Storage.....   | 7  |
| 1.7   | Alternative Storage Systems.....   | 7  |
| 2.    | Environmental Protection Measures.....   | 7  |
| 2.1   | Siting Consideration.....  | 7  |
| 2.2   | Local Spill Response Units.....  | 8  |
| 2.3   | Lease Berm and Production Flow Control System Requirements.....                        | 9  |
| 3.    | Aboveground Storage Tank.....  | 9  |
| 3.1   | Aboveground Storage Tank Classification.....   | 9  |
| 3.2   | Single Walled Tank with Internal Volume Equal To or Greater Than 5m <sup>3</sup> ..... | 10 |
| 3.3   | Double Walled Tank Requirements.....   | 10 |
| 3.4   | Single Walled Tanks with Internal Volume Less Than 5 m <sup>3</sup> .....              | 10 |
| 3.5   | New and Existing Storage Tank Inspection Requirements.....                             | 11 |
| 3.5.1 | New Storage Tanks.....   | 11 |
| 3.5.2 | Existing Storage Tanks.....  | 11 |
| 3.5.3 | Scheduled Tank Inspection Program.....   | 12 |
| 3.6   | Secondary Containment.....   | 12 |
| 3.6.1 | Synthetic Liner System Specifications.....   | 12 |
| 3.6.2 | Clay Liner System Specification.....   | 13 |
| 3.6.3 | Impermeable Dykes and Berms.....   | 13 |
| 4.    | Underground Storage Tanks.....   | 15 |
| 5.    | Storage Container(s) Requirements.....   | 15 |
| 5.1   | Container Definitions and General Requirements.....                                    | 15 |
| 5.2   | Container Secondary Containment System.....  | 16 |
| 5.3   | Container Weather Protection.....  | 16 |



Appendix 1 – Isolation Distance For Facilities and Wells .....17

Appendix 2 – Equipment Spacing Requirements .....18

Appendix 3 - Surface Water Discharge Criteria.....21

Appendix 4 – Underground Storage Tank (UST) Requirements.....22

Glossary .....24

## 1. General Discussions

### 1.1 General Discussions

This document provides comprehensive storage standards for the Saskatchewan upstream petroleum industry. The purpose of the storage standard is to ensure that materials produced, generated and used by the upstream petroleum industry are stored in an environmentally responsible manner.

The Ministry of Energy and Resources (ER) recommends all operators employ the following environmental and safety measures:

- Select storage methods that minimize potential impacts to the environment
- Implement operating procedures, maintenance practices, and inspection programs to prevent failures, spills and leaks from storage vessels and associated equipment
- Store materials in such a manner that:
  - They do not generate extreme heat, pressure or cause fire or explosion
  - They do not produce uncontrolled fumes/gases that pose a risk of fire or explosion
  - They do not damage the structural integrity of a storage vessel
- Incompatible materials are segregated to prevent contact with other incompatible materials and from contaminating benign materials

The design, construction and operation of storage tanks, containers and facilities shall meet applicable industry standards and comply with ER's legislation, regulations and any applicable requirements of other regulatory agencies. The compliance of this document does not release the operator from its responsibilities to comply with all applicable municipal, provincial and/or federal requirements applicable to their storage facility or storage devices.

The use of flare pits as storage receptacles is strictly prohibited in Saskatchewan. The deadline for the decommissioning of flare pits was January 1, 2004, unless otherwise approved in writing by ER. Any remaining unremediated flare pits must be reported to ER immediately and a decommissioning plan submitted. Contaminated flare pits shall be excavated and remediated to ER's requirements as soon as possible. Failure to comply with this requirement may lead to the suspension of the license or other legislative actions.

Earthen pits may be used for oily and salt water storage in the case of emergency. Any earthen pit to be used as storage for oily and salt water waste must follow all requirements of ER's Guideline GL 97-01 "Guideline for the Construction and Monitoring of Oily Byproduct Storage Structures in Saskatchewan".



## 1.2 Applicable Facilities

The standards specified in this document apply to all upstream petroleum sites and facilities including but not limited to; oil and gas production facilities (batteries, compressors, gas processing plants, oil and gas wells), fieldgates, custom treating facilities, transfer stations, metering stations, sand injection facilities, skimming operations, sloop injection facilities, water injection facilities, EOR injection facilities and waste processing facilities.

The following facilities and activities are exempt from these storage standards:

- Oily byproduct storage structures (OBSST) and desand pits (must comply with the requirements of GL 97-01)
- Storage of drilling wastes (must comply with the requirements of GL 99-01)
- Storage of frac sand and fluids (must comply with the requirements of GL 2000-01)
- Petrochemical Refineries (Saskatchewan Environment)
- Pipelines and Pipeline Facilities licensed under *The Pipelines Act, 1998*. Upon request by ER, the pipeline licensee shall provide document of proof
- Pipeline Storage Facilities Regulated by the National Energy Board (NEB), unless otherwise specified in writing by the NEB

## 1.3 Applicable Materials

Any material(s) produced, generated or used by the upstream industry shall be stored in accordance with these standards. Including but not limited to the following:

- All upstream oil and gas products, byproducts or wastes generated during exploration, handling, processing, recovery, storage, testing, transferring, transporting and treating of primary petroleum resources, other than exempted as above
- Any material contaminated with any of the above described materials
- Refined chemicals and refined chemical wastes used directly or generated at upstream facilities and oil and gas sites

## 1.4 Exempted Materials

The S-01 Storage Standards do not apply to the following:

- Natural gas liquids (C2 to C4, pressurized vessels)
- Storage of water that meets unrestricted discharge or irrigation discharge criteria as specified in Appendix 3: Surface Water Discharge Criteria
- Products, byproducts or wastes associated with petrochemical refining processes
- Sewage, scrap metal, garbage and construction materials
- Pressurized vessels regulated under *The Boiler and Pressure Vessel Act*
- Man-made radioisotopes regulated by The Canadian Nuclear Safety Commission

However, pressurized vessels used to store natural gas liquids and vessels regulated under *The Boiler and Pressure Vessel Safety Act* shall be spaced in accordance with the equipment spacing requirements in Appendix 2.



### 1.5 Storage Duration

Refined chemical products stored at upstream sites shall be used or disposed of within two years. The storage duration for oilfield wastes, refined chemical wastes, spent filters and empty containers at an upstream site shall not exceed two years. The prescribed storage duration does not apply to production products. The operator shall be able to demonstrate that the product has not exceeded the prescribed storage duration.

### 1.6 Temporary Storage

The temporary storage of produced products, byproducts and wastes from upstream facilities and wells must not exceed one year unless written permission is obtained from the appropriate ER's field office. Temporary storage includes plant turnarounds, construction operations, containment and clean-up of spills, site remediation, emergency pop tanks, testing and servicing operations. At the end of the temporary storage operation, materials must be treated and processed or properly disposed of.

The temporary storage area shall be designed to contain and minimize the discharge of contaminants into the environment. The containment features may include tanks, impervious liners, dykes and/or other measures. The operator should employ an appropriate level of protection and containment based on site specific conditions, duration of storage and risk posed to the environment by the material stored. The temporary storage structure shall be decommissioned immediately after its use. The area impacted shall be assessed and remediated in accordance with ER's requirements.

### 1.7 Alternative Storage Systems

The provisions of this guide are intended to permit the use of alternative storage systems if it can be shown that the materials, systems, equipment, procedures, or new technologies can meet the objectives and intent of the requirements described in the guide. Licensees wishing to implement storage systems alternative to the requirements outlined in this guide must include the design details in the application for a facility licence. The application must contain sufficient information to substantiate that an equivalent level of environmental protection and safety will be achieved by the proposed storage system.

## 2. Environmental Protection Measures

### 2.1 Siting Consideration

If there are no applicable regulations made pursuant to *The Fire Prevention Act, 1992*, oil or water tanks or a battery of tanks are to be located so that the outer perimeter of any dyke is not less than 75 metres from any right of way of any surface improvement, occupied dwelling, permanent farm building, public facility or urban centre or 100 metres from any surface water body. Please note, power lines into your facility, your own surveyed access road and your own flowline are exempt.



New storage facilities shall be located to meet the following criteria unless in the opinion of the minister, a shorter distance is justified by special circumstances:

- as per isolation distances specified in Appendix 1
- are readily accessible for fire fighting and other emergency procedures
- are not located in a flood plain of 1:100 years
- the outer perimeter of the berm shall be at least 100 metres away from the high water mark of permanent surface water bodies and wetlands
- at least 200 metres from a private or community well
- where noise levels, odors or emissions may significantly impact the adjacent residents, the storage facilities should be located at least 500 metres away, unless the operators can provide mitigating system(s) (see Appendix 1)
- glycol dehydrators should be sited and/or benzene emissions reduced to comply with Saskatchewan Upstream Petroleum Industry Guideline to Reduce Emissions from Glycol Dehydrators S-18

All facilities shall have at the entrance to the facility a sign indicating the operator (owner's) name, emergency phone number and the legal land description.

Unless otherwise directed by ER, all facilities and well sites shall be fenced if it is reasonable to expect that they will come in contact with livestock, children and/or the public. If livestock are to be moved in to a new area, a fence shall be constructed at the landowner's request. In order to receive ER's waiver for fencing requirements, the licensee must provide land owner's consent or provide application to the appropriate field office as to why a fence should not be constructed.

All equipment at a facility or site shall be spaced in accordance with the equipment spacing requirement in Appendix 2.

## **2.2 Local Spill Response Units**

It is a condition of both the well and facility licence that all licensees be a member in good standing of an Area Spill Response Unit. Licenses failing to uphold membership can have their licence suspended. Operators who are members in good standing of an Area Spill Response Unit or Western Canada Spill Services are only required to provide the name(s) and phone number(s) of their emergency contact personnel. The operators must maintain their membership with the Area Spill Response Unit and participate in the annual spill training exercise(s). If an operator fails to meet and maintain these requirements, the operator shall immediately register a detailed spill contingency plan as outlined below and make available all necessary equipment and resources to deal with any emergency situation.

All other operators shall register a copy of a detailed spill contingency plan with ER and local emergency measure organizations. In addition, they shall make available all necessary equipment and resources required to deal with emergency situations.



The detailed spill contingency plan shall include:

- A list of emergency contact personnel and their phone numbers (must include company representative phone number who is available 24 hours a day for emergency)
- Details on the spill assessment process
- Details on procedures for containment and recovery of spilled products
- List of all sites operated by the company that may impact public safety or may be located in a sensitive environment, and a detailed description of an emergency contingency plan for these sites
- A list of contractors who will provide the recovery and clean-up services
- A list of equipment available to be used for containment and recovery, together with spilled product recovery procedures
- A spill notification and public and media communication process

### **2.3 Lease Berm and Production Flow Control System Requirements**

In addition to a dyke around the tank or battery of tanks, all wells or facilities may require a lease berm and/or contoured lease. The purpose of a lease berm is to contain significant releases from the well head, pumping devices, associated piping and equipment on the lease. A lease berm or a contoured lease is required

- when it is specified in the well or facility license;
- when ordered verbally or in writing by ER;
- where the ground elevation of the well center is 1.5 metres or higher than the edge of the lease; or
- where it is reasonable to believe that a domestic water supply, dugout, surface water body or other sensitive features will be impacted by produced fluid released from a well before an operator can intervene

An appropriately designed and maintained stuffing box system that prevents leakage OR secondary containment immediately surrounding the stuffing box to contain release of well-bore fluids is required for all oil wells. In addition, the entire production flow control system consisting of wellhead, stuffing box, flow line, storage tanks and transfer points must be maintained to prevent or minimize environmental impact for all wells. Failure to comply with these requirements can result in shutting-in of the well.

## **3. Aboveground Storage Tank**

### **3.1 Aboveground Storage Tank Classification**

Aboveground Storage Tanks (AST) have an internal volume greater than 1 m<sup>3</sup> (1000 litres) and more than ninety percent of its capacity is above surface grade. An acceptable aboveground storage tank system includes:

1. New welded steel tanks manufactured to American Petroleum Institute (API) 12D, 12F, 620 and 650 standards.
2. Reconditioned and used welded steel tanks that meet the following standards:
  - inspected by an individual with appropriate qualifications and training;
  - inspected as per applicable API standards; and
  - repaired, altered or reconstructed as per applicable API standards.
3. Fiberglass reinforced plastic tanks manufactured to API 12P may be used at all facilities.



4. Riveted tanks may be used for temporary storage of fluids caused by emergencies or upset conditions from normal operations (i.e. pop-tanks). All fluids shall be removed from the tank as soon as reasonably possible. Maximum storage duration shall not exceed 90 days.
5. Other tanks such as skid mounted tanks, bolted tanks, portable tanks, plastic tanks, totes, slips, chemical and bulk type may be used at any upstream facility if they are installed and used in accordance with the manufacturer's instructions or recommendations.

Aboveground storage tanks refer to tanks used primarily for the storage of fluids. Aboveground tanks shall be used only for those applications specified in their respective standards. The operator shall not use the tank for any purpose contrary to manufacturer's instructions, recommendation or any applicable industry standards.

### 3.2 Single Walled Tank with Internal Volume Equal To or Greater Than 5m<sup>3</sup>

General construction criteria for new aboveground storage tanks with an internal volume equal to or greater than 5 m<sup>3</sup> are as follows:

- Steel tanks should be externally coated or have cathodic protection if they are exposed to a corrosive environment.
- Steel tanks shall be internally coated where the tank is used to store corrosive (corrosive liquids have a pH less than 5 or greater than 10).
- Steel tanks used for storage of salt water shall be internally coated, cathodically protected or otherwise protected against corrosion by means acceptable to ER.
- All tanks shall be equipped with secondary containment system and leak detection as specified in section 3.6.
- All tanks shall be equipped with transfer spill preventers.
- All tanks shall be equipped with one or more of the following overfill protection systems: automatic shut-off devices on pumps, high level alarms, two-stage alarms, visual indicators or any appropriate device that will prevent overfilling. If an automatic shut off device is not employed appropriate operating practices must be in place to prevent the overfilling of tanks.

### 3.3 Double Walled Tank Requirements

Double walled tanks shall have the following features:

- A functional leak detection system in the interstitial space between the two walls
- An overfill protection system and corrosion protection system (where required)
- All tanks shall be equipped with transfer spill preventers
- Tank dyke is not required

### 3.4 Single Walled Tanks with Internal Volume Less Than 5 m<sup>3</sup>

Aboveground storage tanks with a total internal volume greater than 1 m<sup>3</sup> but less than 5 m<sup>3</sup> and all pop tanks, dog dishes and emergency storage devices shall comply with the following requirements:

- A monthly visual inspection of the storage devices and storage area
- Any abnormal circumstances shall be documented
- Description of the circumstance (when, what, where, why)
- Action taken to correct the problem



- Must be grounded to eliminate any static electricity and a proper deflection plate shall be installed to prevent splashing
- A mechanical integrity test is not required
- Secondary containment is not necessary, however, the operator must implement a physical barrier or operational procedure to mitigate impact to the environment, if an accidental release occurs. When the aggregate storage capacity of these tanks exceeds 15 m<sup>3</sup> on a lease, secondary containment is required
- A dog dish open top tank that is used only to store blow down water (produced water and formation mud) from a shallow gas well can include plastic tubs, fiberglass reinforced plastic tanks or steel tanks. Corrugated steel piping or rings lined with synthetic liners, evaporation ponds, concrete or earthen pits (lined or unlined) are not an acceptable dog dish, any new installation of such devices is prohibited

### **3.5 New and Existing Storage Tank Inspection Requirements**

#### **3.5.1 New Storage Tanks**

Aboveground storage tanks installed after April 1, 2002 shall be installed in accordance with the standards specified in this document. Beginning April 1, 2012 any tank that is ten years old or greater will not be considered a new storage tank.

#### **3.5.2 Existing Storage Tanks**

All aboveground storage tanks installed before April 1, 2002 which do not meet the requirements of the applicable standards specified in this document shall be inspected every five years to verify mechanical integrity. Beginning April 1, 2012, any tank that is ten years old or greater will be considered an "Existing Storage Tank" and must be inspected every five years.

Specifically, at least 20 percent of the total tank population shall be inspected annually, until one hundred percent of the existing tanks are inspected over a five-year period. Upon request, ER may allow the operator to perform inspections on any percentage of the total tank population in any one year. Thereafter, an ongoing testing/inspection program shall be conducted

The operator may conduct inspections in accordance with applicable API standards or design their own mechanical integrity testing program. The inspection should be completed by a properly certified tank inspector. A report verifying the mechanical integrity of the tank must be kept on record for the life of the tank. The operator shall notify ER of any alternate mechanical integrity test(s) or inspection schedule(s) in writing. The operator must wait to receive written permission from ER prior to proceeding.

The operator may use an existing tank(s) until the tank fails (a spill occurs due to failure) or fails the mechanical integrity test or as otherwise ordered by ER. If any of these events occur, the operator shall initiate corrective actions. These actions must be documented and may include

- repairing and re-testing the tank, and then install the tank as per the standards specified in this document.
- replacing the tank and installing it as per the new standards.
- assessing the area surrounding the tank for contamination and conducting clean-up activities as required.



- notifying the appropriate ECON field office if the failure of the storage device results in a spill of reportable quantity (2.0m<sup>3</sup> on-lease and any amount off-lease).
- conducting any corrective actions ordered by ER.

### 3.5.3 Scheduled Tank Inspection Program

#### New Tanks:

- Monthly visual inspection of the secondary containment and leak detection system.
- Any abnormal circumstances shall be documented on the inspection sheet.
- Description of the circumstance (when, what, where, why).
- Action taken to correct the problem.

#### Existing Tanks:

- Monthly visual inspection of the tank, storage area for leaks or spills.
- Any abnormal circumstances shall be documented on the inspection sheet.
- Description of the circumstance (when, what, where, why).
- Action taken to correct the problem.
- Mechanical integrity tests as described in section 3.5.2.

## 3.6 Secondary Containment

Operators shall provide an appropriate secondary containment system for aboveground storage tanks with an internal volume equal to or greater than 5m<sup>3</sup> for any of the following products:

- Refined Product: refined chemical product such as acids, amine, base, diesel, gasoline, glycol, methanol and solvents.
- Produced Products: upstream oil and gas products (unrefined), byproducts, wastes and materials contaminated with produced products. They include, but not limited to, crude oil, condensate, drilling fluids, drilling waste, frac fluids, frac sands, liquid petroleum gas, oily byproduct, produced water, produced sand and any other material contaminated with produced products

Acceptable secondary containment systems for this purpose are double walled tanks, synthetic liner and clay liner systems with an impermeable dyke.

### 3.6.1 Synthetic Liner System Specifications

#### SL-1: Single Synthetic Liner System

- Primary liner to consist of synthetic liner directly over a minimum of 300mm thick clay subsoil.
- Geomembrane that is impervious to, resistant to, inert to or compatible with the material it is intended to contain.
- Provides a hydraulic conductivity less than 1.0X10<sup>-10</sup> cm/s, or equivalent performance and durability.
- Layer of protective covering for the primary liner, as required.
- An impermeable dyke (liner must be anchored to the dyke).
- Leak detection by incorporation of porous material, such as sand or gravel, over the liner and underneath the tanks in conjunction with a sloped/graded system to allow any leakage



to move preferentially through the porous material to a visually marked leak detection/collection area or sump within the dyked area.

- Depending on the site specific situation ER may require additional leak detection provision that may include subliner leakage detection devices (see figure 1), rubber coaster system or raised tanks.
- Monthly visual inspections of tanks and the surface of the dyked area for evidence of problems, damage or leakage.

### 3.6.2 Clay Liner System Specification

Clay Prepared Liner with Impermeable Dyke

- Clay liner to consist 500 millimetres of clay that is scarified then mechanically compacted to Standard Proctor Density equal to or greater than 95% (at optimum moisture level) and installed in lifts of 100mm or less. Minimum hydraulic conductivity must be less than or equal to  $1.0 \times 10^{-6}$  cm/second ( $1.0 \times 10^{-8}$  m/second).
- The bottom of the pit must be separated from the groundwater table (as measured at the time of installation) by at least 500 mm of continuous impermeable subsoil and 500 mm of prepared clay as mentioned above.
- Acceptable soil hydraulic conductivity testing methods include:
  - Laboratory Evaluation of Candidate Liners for Secondary Containment of Petroleum Products API Publication Number 328, 1995;
  - Overview of Soil Permeability Test Methods, API Publication Number 351, April 1999;
  - Any method developed and directly implemented by or implemented under supervision of an APEGS registered Professional Engineer with appropriate experience and knowledge in testing hydraulic conductivity.
- The specification of the clayey material used for the liner and the details of the liner construction (quality assurance/quality control [QA/QC] data) must be documented and made available to ER staff upon request.
- Leak detection by subliner leakage detection device (see figure 1), rubber coaster system or raised tanks.
- Monthly visual inspections of tanks and the surface of the dyked area for evidence of problems, damage or leakage.

### 3.6.3 Impermeable Dykes and Berms

An impermeable dyke is a dyke completely surrounding a storage device(s) which is constructed of clay, concrete, steel and/or a synthetic material that will not deteriorate or develop leaks during the projected life of the structure. It must withstand the hydrostatic head associated with it being full of liquid and sized at least 110% of the capacity of the tank when the dyked area contains one tank, or when the dyked area contains more than one tank, 100% of the volume of the largest tank plus 10% of the aggregate capacity of all other tanks. There shall be no opening in the dyke (e.g. dyke drains). Clay dykes must comply with all of the same requirements of a clay liner and must be maintained in good condition all of the time. The area encompassed by the dyke shall be kept free from extraneous combustible material.

A lease berm (includes contoured leases) is a dyke surrounding the whole or part of an oil and gas lease that is capable of containing produced fluid released from any operation on the lease and prevent large amounts of surface water from entering and flooding the lease.



**Figure 1. Aboveground Storage Tank Clay Liner Leak Detection System**

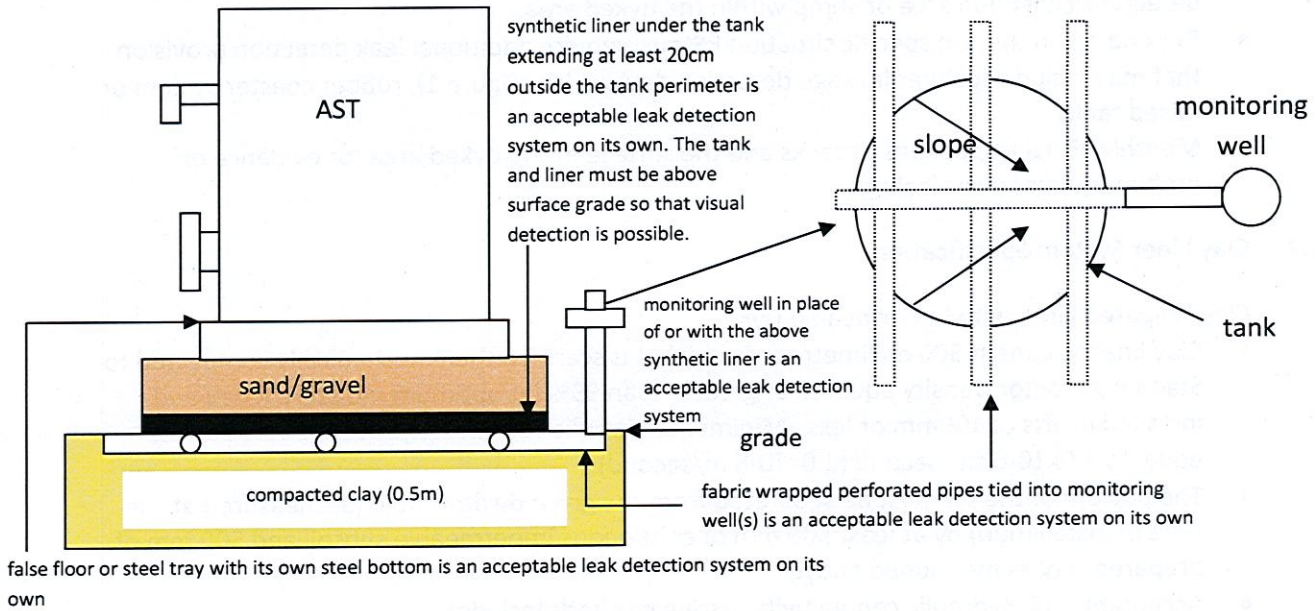

**Figure 2. Example Sketch of a Contoured Lease**

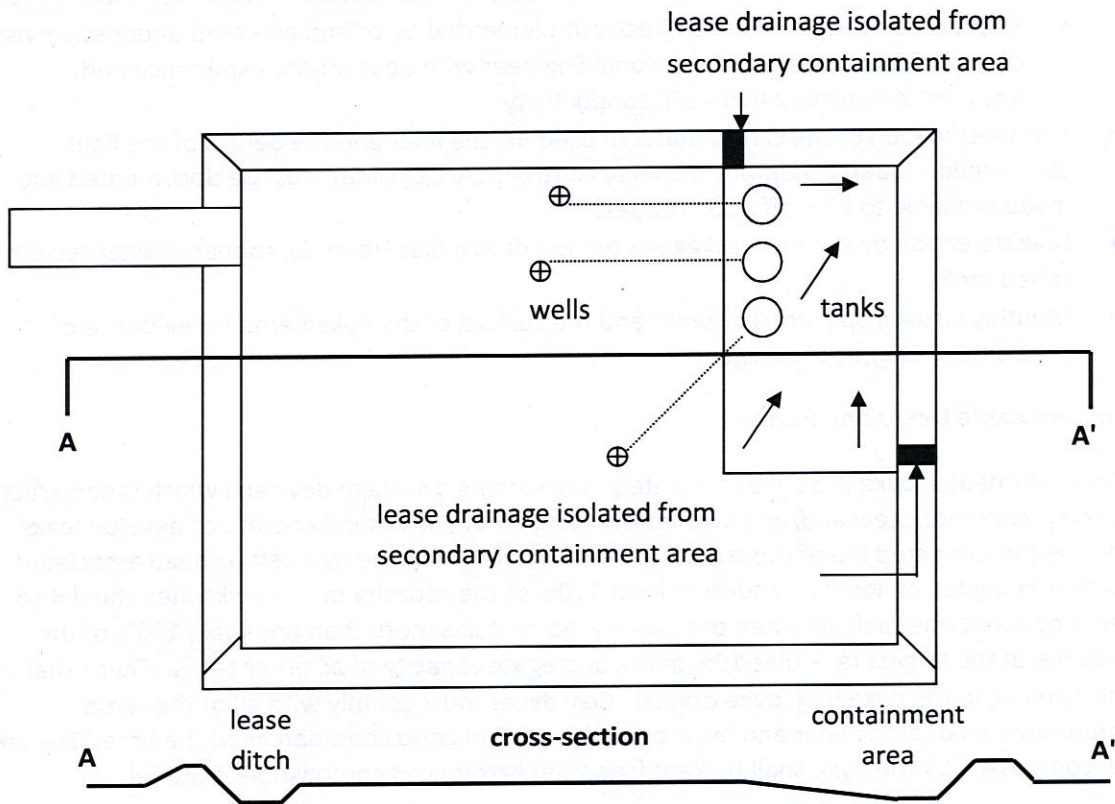

Please note this sketch is only provided as an example, the operator should develop their own design based on site-specific conditions.

#### 4. Underground Storage Tanks

Installation of new underground storage tanks is prohibited except by special application as outlined in Appendix 4. ER recognizes that in some rare circumstances operators have no alternatives other than to install an underground storage tank. Where the operator can demonstrate (in writing) that no alternative exists, ER may provide permission to install underground storage tank(s); the permission may be site, pool or area specific. In all circumstances, new underground storage tanks shall be installed in accordance with requirements specified in Appendix 4.

All existing underground storage tanks (including dual walled underground storage tanks) and piping shall be precision tested/inspected once every three years to verify the mechanical integrity of the existing storage device. In the event the existing underground storage tank(s) leaks or fails the above-required test(s), the operator shall notify the appropriate ER field office, and initiate corrective actions. The actions must be documented. Those actions may include

- replacing the tank with an aboveground storage tank.
- assessing the area surrounding the tank for contamination, conducting clean-up activities as required and conducting any further corrective actions ordered by ER.

Shallow gas operations (Saskatchewan Area Three, producing natural gas from above the top of the Fish Scales formation) are permitted to install underground storage tanks without applying for permission provided they abide by all provisions in this section and the requirements specified in Appendix 4.

#### 5. Storage Container(s) Requirements

##### 5.1 Container Definitions and General Requirements

All hazardous materials or produced byproducts and waste containers shall be contained to prevent release into the environment, and stored to provide minimum exposure to the elements.

A container or a collection of containers with an aggregate volume less than 1 m<sup>3</sup> (1000 litres) at one site does not require secondary containment or weather protection. Containers must be stored in such a manner so that a visual leak detection of the bottom of the container surface can be conducted. Secondary containment is required where a release cannot be contained on-site and there is a reasonable expectation that a release will impact a stream, water body and groundwater.

A collection of containers with an aggregate volume greater than 1 m<sup>3</sup> (e.g. approximately five 45-gallon drums) at one site requires secondary containment and weather protection.

All containers must be stored and handled in a manner to maintain the integrity of the containers and to protect against spills. For example, extra caution must be exercised when handling and storing bottles and bags of chemicals.



## 5.2 Container Secondary Containment System

Secondary containment systems for containers (e.g. dykes, curbs, collection trays) must be constructed of materials that are impervious to the materials being stored and shall be

- constructed of material that will not react with any material being stored and which has no openings that may provide direct connection to the ground underneath the container;
- a minimum height of 15cm, or have a net capacity greater than that of the largest container within the storage area, or 15% of the total volume of all containers in the storage area, whichever is greater. Containment may be achieved via the proper use of at least one of the following devices:
  - Storage compounds which meet the secondary containment criteria for Aboveground storage tanks;
  - Metal, plastic bins or overpacks;
  - Drip trays or spill pallets; or
  - Any other devices deemed to be acceptable by ER.

## 5.3 Container Weather Protection

Weather protection is intended to preserve the condition of the primary container and hence the usefulness of the material contained therein. Weather protection is considered to be a physical cover/coating made of weather resistant materials (i.e., plastic) over the containers.

Acceptable weather protection devices include:

- Covered metal or plastic bins
- Overpacks
- Storage docks possessing a roof and walls on three sides
- Secured canvas, plastic tarpaulins or weather resistant plastic covers
- Protective coatings and corrosion resistant paints
- Storage trailers and buildings

All containers must be visually inspected for surface damage and leaks on a daily basis at a manned facility or on each site visit at an unmanned site. Any abnormal circumstances must be documented.

Appendix 1 – Isolation Distance For Facilities and Wells

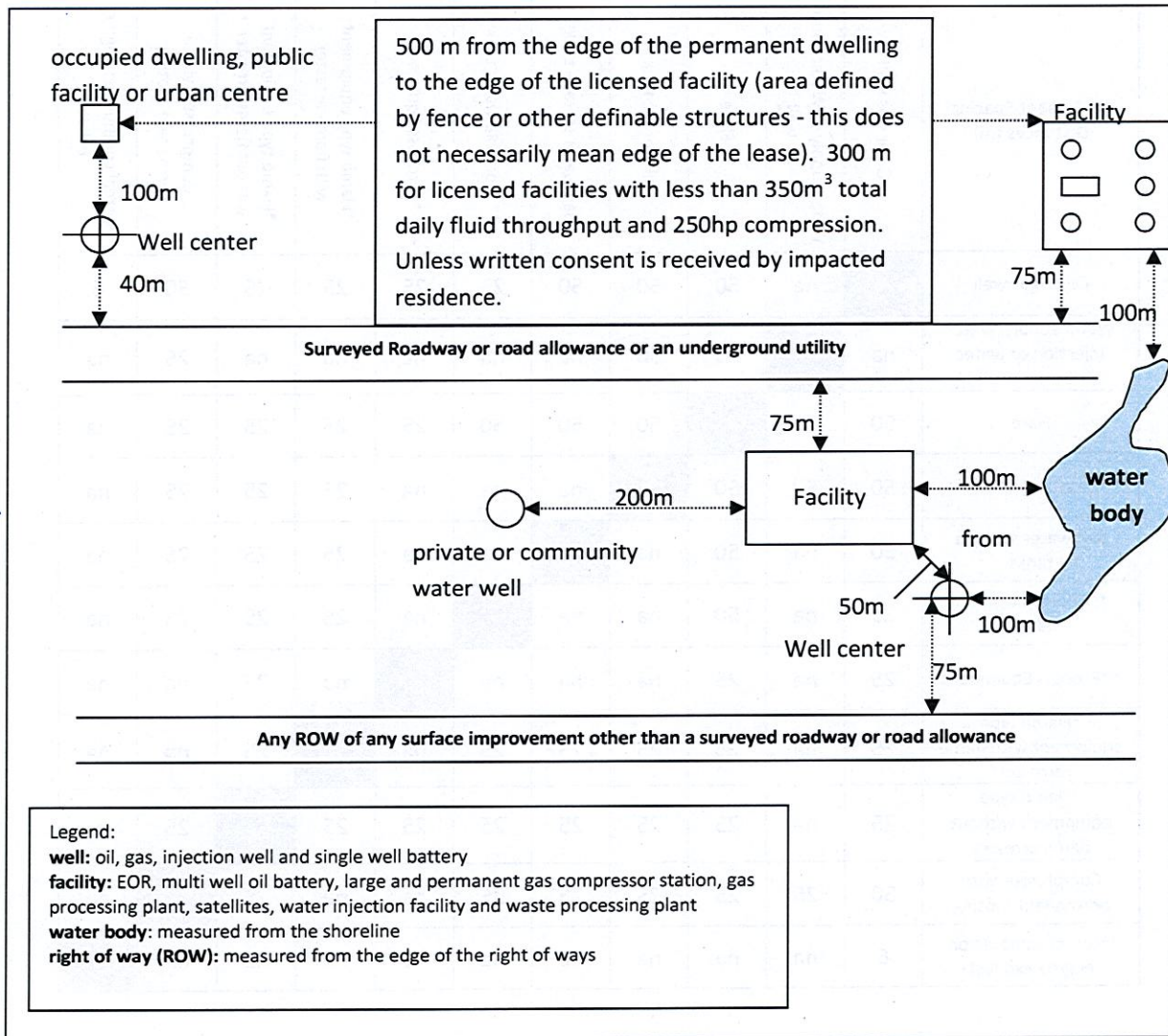



Appendix 2 – Equipment Spacing Requirements

| Equipment Spacing Distances (m)                      | Oil or Gas well | Water supply of Water source well | Flare | Oil Storage tanks | Salt water storage tanks | ***Portable water tanks | **Process Equipment | *Flame type equipment with flame arrester | *Flame type equipment without flame arrester | Compressor with permanent footing | Internal combustion engine exhaust |
|--|-----------------|-----------------------------------|-------|-------------------|--------------------------|-------------------------|---------------------|---|--|-----------------------------------|------------------------------------|
| Oil or gas well                                      | na              | na                                | 50    | 50                | 50                       | 25                      | 25                  | 25  | 25   | 50                                | 6                                  |
| Water supply, water injection or water disposal well | na              | na                                | 25    | 50                | na                       | na                      | na                  | na  | na   | 25                                | na                                 |
| Flare  | 50              | 25                                | na    | 50                | 50                       | 50                      | 25                  | 25  | 25   | 25                                | na                                 |
| Oil storage tanks                                    | 50              | 50                                | 50    | na                | na                       | na                      | na                  | 25  | 25   | 25                                | na                                 |
| Salt water storage tanks                             | 50              | na                                | 50    | na                | na                       | na                      | na                  | 25  | 25   | 25                                | na                                 |
| ***Portable water tanks                              | 25              | na                                | 50    | na                | na                       | na                      | na                  | 25  | 25   | 25                                | na                                 |
| **Process Equipment                                  | 25              | na                                | 25    | na                | na                       | na                      | na                  | na  | 25   | na                                | na                                 |
| *Flame type equipment with flame arrester            | 25              | na                                | 25    | 25                | 25                       | 25                      | na                  | na  | 25   | na                                | na                                 |
| *Flame type equipment without flame arrester         | 25              | na                                | 25    | 25                | 25                       | 25                      | 25                  | 25  | na   | 25                                | na                                 |
| Compressor with permanent footing                    | 50              | 25                                | 25    | 25                | 25                       | 25                      | na                  | na  | 25   | na                                | na                                 |
| Internal combustion engine exhaust                   | 6               | na                                | na    | na                | na                       | na                      | na                  | na  | na   | na                                | na                                 |

\* **Flame type equipment** includes any open flame equipment, other heating device or electrical device that has open ignition and/or could potentially cause a fire or explosion. For the purpose of equipment spacing, flame type equipment includes, but is not limited to, steam boilers, free water knock-outs, dehydrators, generators, heaters, treaters, diesel engines without automatic air shut offs and heated water tanks on a skid.

\*\* **Process equipment** includes any non-flame type equipment used in the upstream petroleum recovery or treatment process such as, but not limited to, amine tank, pop tank, flare knockout drum (N/A with appropriate overfill protection and flame arrester), scrubber, sweetener and separator. Process equipment generally does not have a permanent footing.

\*\*\* **Portable Water tanks** are skid mounted, less than 65m<sup>3</sup> and are not heated.



**Diagram 1. Typical Equipment Spacing Diagram**

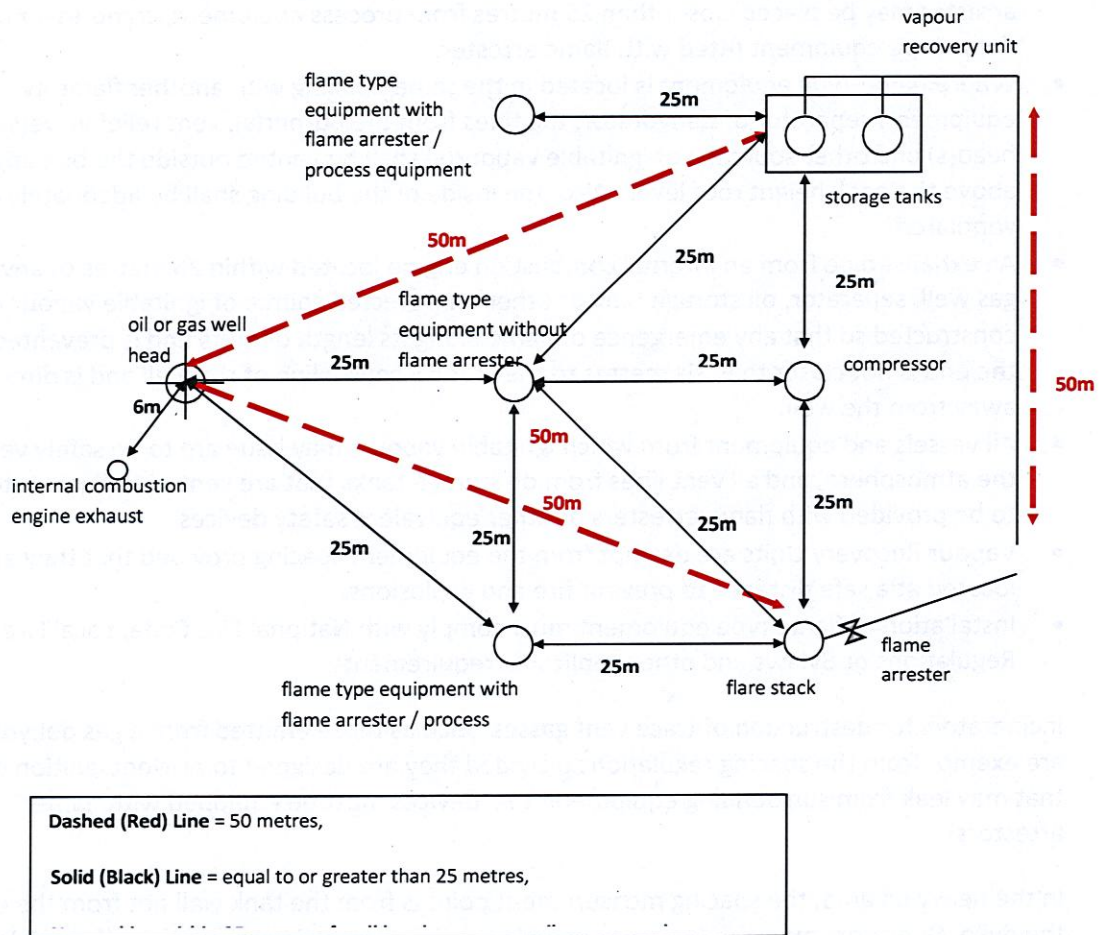

**Equipment Spacing Details:**

Equipment spacing measurement points:

- Where a dyke is present, the measurement shall be from the outer perimeter of the dyke of the object to the nearest outer perimeter of the dyke of the target object (if dyke is present) or to the nearest outer wall of the target object (if dyke not present);
- Where dyke is not present, the outer wall of the target object to the nearest outer wall of the target object; and
- For wells, the measurement shall be from the well centre to the target object's outer wall or outer perimeter of the dyke facing the well.

"na" means equipment spacing requirements do not apply however must comply with National Fire Code, Local Fire Regulations, Canadian Electrical Code, Local Bylaws and/or other applicable requirements.

**Flame Type Equipment:**

- Flame-type equipment where air intake of the burner is fitted with an adequate flame arrester may be placed closer than 25 metres from process equipment, compressor or other flame type equipment fitted with flame arrester.
- Where flame-type equipment is located in the same building with another flame-type equipment, separator or dehydrator, the flues from the burner(s), vent relief valve(s), safety head(s) and other source(s) of ignitable vapour(s) shall be vented outside the building and above the peak height roof level. Also, the inside of the building shall be adequately cross-ventilated.
- An exhaust pipe from an internal combustion engine located within 25 metres of any oil or gas well, separator, oil storage tank or other unprotected source of ignitable vapour is to be constructed so that any emergence of flame along its length or at its end is prevented; and the end is not closer than six metres to the vertical centre line of the well and is directed away from the well.
- All vessels and equipment from which ignitable vapours may issue are to be safely vented to the atmosphere, and all vent lines from oil storage tanks that are vented to flare system are to be provided with flame arresters or other equivalent safety devices.
- Vapour Recovery Units are exempt from the equipment spacing provided that they are located at a safe distance to prevent fire and explosions.
- Installation of flame type equipment must comply with National Fire Code, Local Fire Regulations or Bylaws and other applicable requirements.

Incinerators for destruction of trace vent gasses, such as those emitted from a gas dehydrator, are exempt from the spacing regulations provided they are designed to prevent ignition of gas that may leak from surrounding equipment. (i.e. devices must be equipped with flame arrestors).

In the heavy oil area, the spacing measurement point is from the tank wall not from the edge of the dyke. Operators may obtain company wide equipment spacing exemptions (from 50m to 25m) for storage of crude oil and salt water in relation to a heavy oil well (this exemption is not available to batteries, facilities or other upstream facilities). Requests must be made in writing and signed by a company executive (i.e. vice president).

Equipment located at existing facilities that were in compliance with the regulations prior to implementation of the new spacing requirements that came into effect January 1st, 2008, are exempt from the new spacing requirements.



**Appendix 3 - Surface Water Discharge Criteria**

**Unrestricted Discharge:** Applies to surface water collected at upstream oil and gas facilities which meets the criteria listed in the unrestricted column in table 1. Landowner consent is required if the water is disposed of on either privately or crown owned land. Operators must comply with other relevant regulatory agency's requirements.

**Irrigation Discharge:** Applies to surface water collected at upstream oil and gas facilities which meets all of the criteria listed in the irrigation column in table 1. If the water is to be used off lease, written landowner consent is required. Operators must comply with other relevant regulatory agency's requirements.

**Controlled Discharge:** Applies to surface water collected at upstream oil and gas facilities which meets the criteria listed in the controlled column in table 1. The operator shall dispose of the water at an approved waste processing facility or disposal well. Operators must comply with other relevant regulatory agency's requirements.

**Table 1. Surface Water Discharge Criteria for Upstream Oil and Gas Facilities**

| <b>Surface water discharge criteria</b>  |   |                       |                       |                   |
|--|---|-----------------------|-----------------------|-------------------|
| <b>Parameters</b>  |   | <b>Unrestricted</b>   | <b>Irrigation</b>     | <b>Controlled</b> |
| <b>Routine Tests</b><br>all surface water must be tested for these parameters and meet the criteria prior to discharge                                   | pH  | 6 to 8                | 6 to 8                | <6 or >8          |
|  | chloride (total)  | ≤500 mg/L             | ≤1000 mg/L            | > 1000 mg/L       |
|  | visible hydrocarbon   | no visible sheen      | no visible sheen      | visible sheen     |
| <b>Special Tests</b><br>these additional tests are required if the surface water has or is suspected of having contacted spill or contaminated materials | oil and grease: hexane extraction (silica gel) gravimetric EPA 1664 | non detect (<10 mg/L) | non detect (<10 mg/L) | >10 mg/L          |
|  | conductance   | ≤1 dS/m               | ≤2 dS/m               | >2 dS/m           |
|  | TDS   | ≤700 mg/L             | ≤1400 mg/L            | > 1400 mg/L       |
|  | Microtox® EC50(15)  | ≥75%                  | ≥75%                  | not required      |

## **Appendix 4 – Underground Storage Tank (UST) Requirements**

Produced water, crude oil, condensate and volatile organic hydrocarbons (VOC with a flashpoint less than 32°C) must be stored in aboveground tanks, unless otherwise approved in writing by ER. The operator will be required to submit a written application justifying any request for below ground installations. UST's can have a maximum volume of 5000 litres and may be constructed using steel, fiberglass reinforced plastic or other appropriate materials.

### **Siting Requirements**

UST's shall be installed with the following hydrogeological conditions:

- Bottom of the UST shall be at least 1.5m above the seasonally high ground water table
- All fluids in the underground storage tank shall be removed as soon as practical, not exceeding 180 days, unless otherwise approved by ER.

### **General Construction Requirements**

General construction criteria for underground storage tank facilities are as follows:

- UST's shall be designed, fabricated, tested and installed to the manufacturer's requirements and to appropriate engineering/construction standards
- Newly installed underground storage tanks and associated piping shall be integrity tested as a complete system prior to being put into service
- Steel tanks shall have internal and external corrosion protection
- Incorporate measures to prevent overfilling and breathing vents shall be designed to prevent plugging-off

### **Secondary Containment Requirements and Leak Detection System**

All UST's containing fluids that do not meet the unconditional or irrigation surface water discharge criteria shall be double-walled and installed with a leak detection system. Vaulted tanks are exempted from this requirement however; they must meet the aboveground storage tank requirements.

An acceptable leak detection system for underground storage tanks includes a weeping tile system installed underneath the tank. The weeping tiles shall be sloped to encourage the collection of fluids. At least one monitoring well shall be completed at the lowest collection point.



### Underground Storage Tank Leak Detection System Profile View

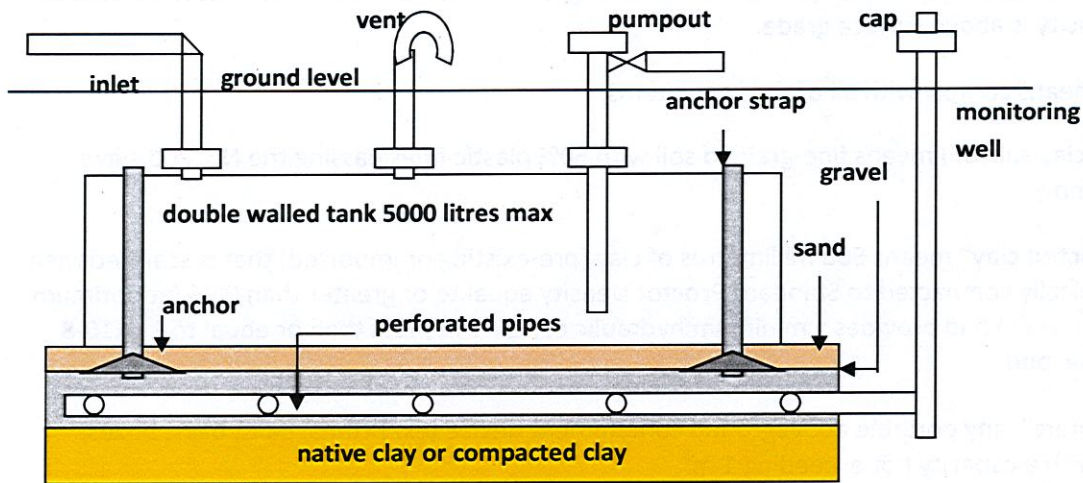

### Underground Storage Tank System Leak Detection System Top View

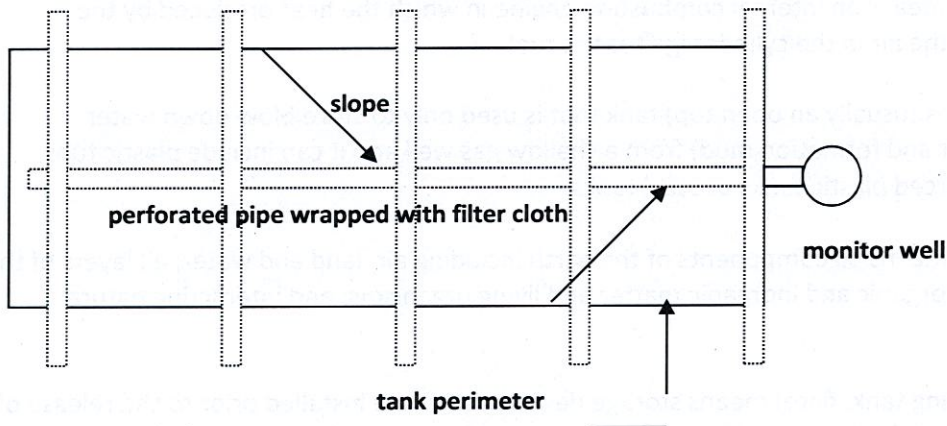

### Scheduled Inspection Program

The interstitial space and monitoring well tied into the weeping tile shall be inspected at least once a month. Any abnormal circumstances shall be documented on the inspection sheet including description of the problem and the action taken to correct the problem.

In the event the underground storage tank(s) fails, the operator shall notify the appropriate ER field office, and immediately initiate corrective actions. The actions must be documented and may include

- repairing the tank and testing as per a new installation.
- replacing the tank and testing as per a new installation.
- assessing the area surrounding the tank for contamination and conducting clean-up activities as required.
- conducting any corrective actions ordered by ER.



## Glossary

**"aboveground storage tank"** (AST) means a storage tank of which more than ninety percent of its' capacity is above surface grade.

**"and"** means comply with all of the listed items.

**"clay"** (clay subsoil) means fine-grained soil with 50% plastic fines passing the No. 200 sieve (0.074 mm).

**"compacted clay"** means 500 millimetres of clay (pre-existing or imported) that is scarified then mechanically compacted to Standard Proctor Density equal to or greater than 95% (at optimum moisture level) and provides a minimum hydraulic conductivity less than or equal to  $1.0 \times 10^{-8}$  metre/second.

**"containers"** any portable aboveground containment device (ex. Drums, pails, bags, boxes, totes) with a capacity not exceeding  $1 \text{ m}^3$ .

**"dehydrator"** means an apparatus designed and used to remove water from gas.

**"diesel engine"** means an internal combustion engine in which the heat produced by the compression of the air in the cylinder ignites the fuel.

**"dog dish"** means (usually an open top) tank that is used only to store blow down water (produced water and formation mud) from a shallow gas well and it can include plastic tubs, fiberglass reinforced plastic tanks or steel tanks.

**"environment"** means all components of the earth including air, land and water; all layers of the atmosphere, all organic and inorganic matter and living organisms; and interacting natural systems.

**"existing"** (existing tank, flare) means storage devices that were installed prior to the release of this document and do not meet the requirements specified in this document.

**"facility"** Any building, structure, installation, equipment, or appurtenance that is connected to or associated with the recovery, development, production, handling, processing, treatment, or disposal of hydrocarbon based resources or any associated substances or wastes.

**"flame type equipment"** means open flame equipment, other heating device or electrical device that has open ignition and/or it could potentially cause a fire or explosion. For the purpose of equipment spacing, flame type equipment includes, but is not limited to, steam boilers, free water knock-outs, dehydrators, generators, heaters, treaters, diesel engines without automatic air shut offs and heated water tanks on a skid.

**"geomembrane"** means a polymeric sheet material that is impervious to liquid - when it maintains its integrity.

**"geosynthetic clay liners"** (GCL) means a layer of processed clay (typically bentonite) either bonded to a geomembrane or fixed between two sheets of geotextile.



**"geotextile"** (geofabric) means a woven or nonwoven sheet material less impervious to liquid than a geomembrane, but more resistant to penetration damage.

**"heavy crude oil"** (heavy oil) means crude oil with density equal to or greater than  $946 \text{ kg/m}^3$ . This definition only applies in the context of this document. It does not apply to any other legislation, regulations, policies, standards or guidelines.

**"high water mark"** is the usual or average level to which a body of water rises at its highest point and remains for sufficient time so as to change the characteristics of the land. In flowing waters (rivers, streams) this refers to the "active channel/bank-full level" which is often the 1:2 year flood flow return level. In inland lakes or wetlands it refers to those parts of the water body bed and banks that are frequently flooded by water so as to leave a mark on the land and where the natural vegetation changes from predominately aquatic vegetation to terrestrial vegetation, (excepting water tolerant species). For reservoirs this refers to normal high operating levels (Full Supply Level).

**"hydraulic conductivity"** is a measure of the ability of a material to transmit fluid, but is dependent on the type of fluid passing through the material.

**"impermeable dyke"** means a dyke completely surrounding a storage device(s) which is constructed of clay, concrete, steel and/or a synthetic material that will not deteriorate or develop leaks during the projected life of the structure. It must withstand the hydrostatic head associated with it, being full of liquid and sized at least 110% of the capacity of the tank when the dyked area contains one tank, or when the dyked area contains more than one tank, 100% of the volume of the largest tank plus 10% of the aggregate capacity of all other tanks. There shall be no opening in the dyke (e.g. dyke drains). It must be maintained in good condition all of the time. The area encompassed by the dyke shall be kept free from extraneous combustible material.

**"internal combustion engine exhaust"** means exhaust from gasoline engines, diesel engines with air shut-offs, natural gas engines, propane engines and their respective exhaust gases and free liquids. It does not include diesel engines with no air shut-offs. There are no spacing requirements applicable to internal combustion engines. The exhausts from these engines must be placed away from an oil and gas wellhead, a minimum distance of 6 metres. The exhausts from these engines must be pointed away from the wellhead, either by orientating the exhaust vertically up or pointing it in the opposite direction from the wellhead. Connecting engine exhaust to a wellhead is strictly prohibited.

**"leak detection system"** means a system or method that is capable of detecting a leak from the primary containment device.

**"lease berm"** (includes contoured leases) means a dyke surrounding the whole or part of an oil and gas lease that is capable of containing produced fluid released from any operation on the lease and prevent large amounts of surface water from entering and flooding the lease.



**"monitoring well"** means a well placed into a specific subsurface zone to enable the sampling of groundwater and to detect the presence of any leachate in the groundwater aquifer or the unsaturated zone.

**"native clayey subsoil"** means 1.5 metres of continuous clay layer that is pre-existing at the site and it is usually not mechanically compacted. It must provide a minimum hydraulic conductivity less than or equal to  $1.0 \times 10^{-6}$  metres/second.

**"natural gas booster compressors"** means a compressor that is portable with trailer or skid mounts and does not have a permanent concrete footing and does not exceed 250 horsepower. The natural gas booster compressors must be installed a minimum of 25 metres from a wellhead. These compressors must comply with the requirements of ER's Guideline for Natural Gas Booster Compressors.

**"new"** (new tanks) means storage devices installed after the effective date specified in this document.

**"oil and gas site"** means any sites or facilities associated with oil and gas exploration, recovery, production, processing, transmission, transportation, treatment and/or disposal. It includes waste processing facilities but it does not include refineries or upgraders.

**"operator"** means licensee of the facility. Where license does not exist, the operator is the company(s) or person(s) who owns the facility or has control on the selection and design of the storage devices installed at the facility.

**"or"** means comply with one of the items.

**"overflow protection system"** means a mechanical or electrical device that is installed in or on a storage tank to prevent the storage tank from being overfilled. Excess capacity within the storage system is considered to be an acceptable overflow protection system. Specifically, a system that is operated in a fashion such that the remaining storage capacity exceeds the amount of fluids that would be added to the system before the next operator visit by a factor of two.

**"permanent storage"** refers to the storage of materials produced, generated, and used by the upstream petroleum industry in a device that is a permanent fixed part of an operating facility. Permanent storage devices may include aboveground storage tanks, containers and bulk pads.

**"permeability"** (hydraulic conductivity) means the rate of discharge of water under laminar flow conditions through a unit cross-sectional area of a porous medium under a unit hydraulic gradient and standard temperature conditions (20°C). Acceptable permeability tests are described in API Publication 351, Overview of Soil Permeability Test Methods.

**"primary containment device"** (storage device) means a device used to physically contain the materials. They include, but are not limited to, tanks and containers.



**"primary production facility"** means all upstream facilities and any other oil and gas sites, including but not limited to gas wells, oil wells, water source wells, disposal wells, Enhanced Oil Recovery projects (steam, water, fire, CO<sub>2</sub>, solvent floods) and waste processing facilities.

**"primary liner"** means the upper most liner that covers all of the area within the dyke and it is keyed into the dyke walls or incorporated into the dyke wall.

**"produced products"** means upstream oil and gas products (unrefined), byproducts, wastes and materials contaminated with produced products. They include, but are not limited to, crude oil, condensate, drilling fluids, drilling waste, frac fluids, frac sands, liquid petroleum gas, oily byproduct, produced water, produced sand and any other material contaminated with produced products.

**"process equipment"** means any non-flame type equipment used in the upstream petroleum recovery or treatment process such as amine tank, pop tank, scrubber, sweetener and separator. Process equipment generally does not have a permanent footing.

**"refined product"** means refined chemical product such as acids, amine, base, diesel, gasoline, glycol, methanol, lube oil and solvents.

**"salt water"** (for the purpose of salt water storage in a steel tanks means) water with a total dissolved solid concentration that is equal to or greater than 4000 mg/L (0.3%).

**"secondary containment"** means an impervious barrier placed between the primary containment device and the ground beneath and surrounding it for the purpose of containing and preventing any leakage from the primary containment device from impacting the environment.

**"secondary containment for indoor aboveground storage tanks"** means building containing storage tanks, pressure piping and compressors must have impermeable floors and be designed to prevent escapes of leaks. Additional provisions of the Saskatchewan Fire Code may apply.

**"secondary liner"** means a liner beneath the primary liner, sometimes separated by a leak detection system that covers all of the area within the dyke.

**"separator"** means an apparatus for separating liquid and gas at the surface as they are produced from a well.

**"sour gas"** means natural gas containing hydrogen sulphide (H<sub>2</sub>S) concentrations equal to or greater than 0.01 moles per kilomole (10 PPM, 0.001%).

**"storage"** means holding of material produced, generated and used by the upstream petroleum industry for a period of time until the products, byproducts or wastes are transported, treated or disposed.

**"storage area"** means a segregated area of an operating facility that is used to store materials produced, generated and used by the upstream petroleum industry in containers and/or tanks and includes all land and associated structures.



**"storage facility"** means a facility dedicated to the storage of materials produced, generated and used by the upstream petroleum industry in containers and/or tanks and includes all land and associated structures.

**"shallow gas operation"** means any operation in Saskatchewan Area Three conducted specifically for the production of natural gas and producing from no lower than the Medicine Hat formation.

**"synthetic liner"** means geomembrane that is impervious to, resistant to, inert to or compatible with the material intended to contain. They include, but not limited to, GCL, polyethylene, polyvinyl chloride, polypropylene, steel, spray-on polymer and/or other synthetic polymers. The liner must be a minimum thickness of 30 mil and provide a hydraulic conductivity less than  $1.0 \times 10^{-10}$  cm/s, or equivalent performance and durability.

**"tank"** means a device designed to contain materials produced, generated and used by the upstream petroleum industry which is constructed of impervious materials that provides structural support.

**"transfer spill preventer"** means a collection device located on the fill pipe or other filling device of a storage tank that is designed to collect any over-delivery during the delivery of the product(s). The operator may choose to implement Best Management Practices (BMP) in place of transfer spill preventer. The BMP should include proper trucker loading procedures, spill prevention procedures such as the plugging of loadlines when not in use and repairing leaking valves. Where the operator BMP is proven inadequate (by a site inspection), ER may require the operator to replace the BMP with transfer spill preventers. The upgrade order may range from a site specific action all the way up to a company wide upgrade.

**"treater"** means an apparatus for separating oil, gas and water at the surface as they are produced from a well.

**"underground storage tanks"** means a storage tank that has at least 10% of its volume below the surface of the ground and includes pipes below the surface of the ground that are connected to a storage tank that is not below the surface of the ground.

**"upstream facility"** means all wells and facilities including oil and gas production sites, pipelines, flowlines and associated equipment, satellites, batteries, metering stations, compressor stations, pump stations, truck unloading stations, and gas plants.

**"vaulted tank"** means a tank that is contained in a concrete or other type of man-made solid walled space (e.g. vault) either below or aboveground level. The vault can be accessed through a man-way or a top that is opened to atmosphere. It may or may not be possible to visually inspect the tank on all sides, however it must be possible to visually detect any leaks from the tank. Vaulted tanks are considered to be aboveground storage tank and the vault is classified as the secondary containment.

**"waste processing facility"** means a system or arrangement of tanks, treaters or other surface equipment that is intended to receive waste material from any oil or gas field operation for processing or disposition.

**"water body"** an area where water flows or is present, whether the flow or the presence of water is continuous, seasonal or intermittent or occurs only during a flood.

**"water table"** is the upper surface of the zone of permanent saturation. Its level migrates from season to season. Operators may determine the water table by excavating a pilot hole or installing groundwater monitoring wells. They may also consult with hydrogeologists, local water well users or check well records.

**"venting"** The intentional controlled release of un-combusted gas.



